

Dual fuel burners for gas and heavy oil at 2 stages progressive (hi-low flame) or PID fully modulating if optional modulation kit (digital type) and feeder (of temperature or pressure) are added.

Fan at high pressurization, high efficiency combustion head with adjustment and high flame stability, pilot flame for gas ignition.

Available versions for natural gas or LPG (to be specified in your order).

Gas train includes working valve, safety valve, minimum gas pressure switch, gas pressure filter-stabilizer and is supplied already assembled, connected and tested.

The adoption of strong metal components makes the burner durable also in heavy duty conditions.

Burners are supplied with nozzle, fuel switch, gasket for installation on boiler, flexible hoses, pre-heated line filter and thermostat, pre-heating tank with low density flanged resistances.

TECHNICAL DATA

MODEL		KN 190/M	KN 250/M
Thermal power min-max*	Mcal/h	300/900-2019	400/1000-2500
	kW	348/10440-2341	464/1160-2900
Flow-rate G20 (NATURAL GAS) min-max*	Nm ³ /h	35/105-236	47/117-292
Flow-rate G31 (LPG) min-max*	Nm ³ /h	14/41-91	18/45-113
Fuel		NATURAL GAS (second family) - LPG (third family)	
Combustible category		2R' 2H' 2L' 2E+' 2Er' 2ELL' 2E(R)B 38/P' 3+' 3P' 38' 3R	
Intermittent operation (min. 1 stop every 24 hours) at 2 stages progressive or modulating			
Allowed environment conditions on running/stock		-15...+40°C/-20...+70°C, rel. humidity max 80%	
Max temperature combustion air	°C	60	60
Min. pressure gas train D2"-FS50 NATURAL GAS/LPG**	mbar	148/86	222/80
Min. pressure gas train DN65-FS65 NATURAL GAS/LPG*	mbar	77/58	113/45
Min. pressure gas train DN80-FS80 NATURAL GAS/LPG**	mbar	58/52	85/36
Min. pressure gas train DN100-FS100 NATURAL GAS/LPG**	mbar	46/46	68/26
Max pressure at the entry of the valves (Pe.max)	mbar	200-500	200-500
HEAVY-OIL flow-rate min-max*	kg/h	30/90-206	40/100-250
Fuel		HEAVY OIL 5°-20° E to 50° C	
Nominal electric power	kW	22	29
Motor fan	kW	5.5	7.5
Motor pump	kW	1.1	1.1
Resistances	kW	15	20
Nominal absorption power	A	13	17
Nominal absorption auxiliary	A	0.7	0.7
Nominal absorption resistances	A	23	31
Power supply		3~400V,1/N~230V-50Hz	
Degree of electric protection		IP44	IP44
Noisiness***min-max	dB(A)	81-82	82-86
Burner weight	kg	170	182

* Reference conditions: Room temperature 20°C - Atmospheric pressure 1013 mbars - Altitude 0m (sea level)

** Least pressure of feeding of the gas to the train to get the maximum power of the burner considering against pressure in chamber of value combustion 0 (zero)

*** Measured sonorous pressure in the laboratory combustion, with functional burner on beta boiler to 1 m of distance (UNI EN ISO 3746 law)

FIRING RATES: Thermal power - Pressure in combustion chamber

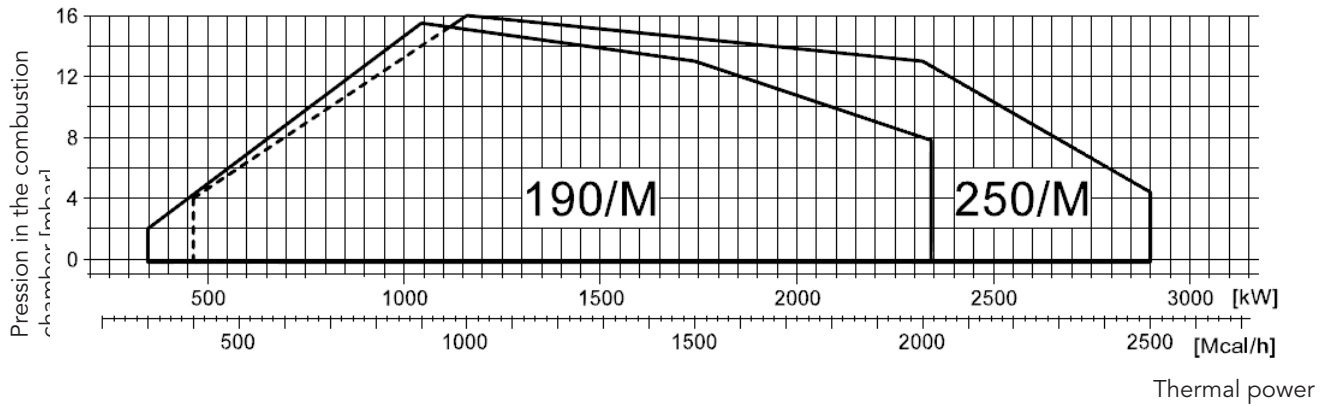

DIMENSIONS (mm)

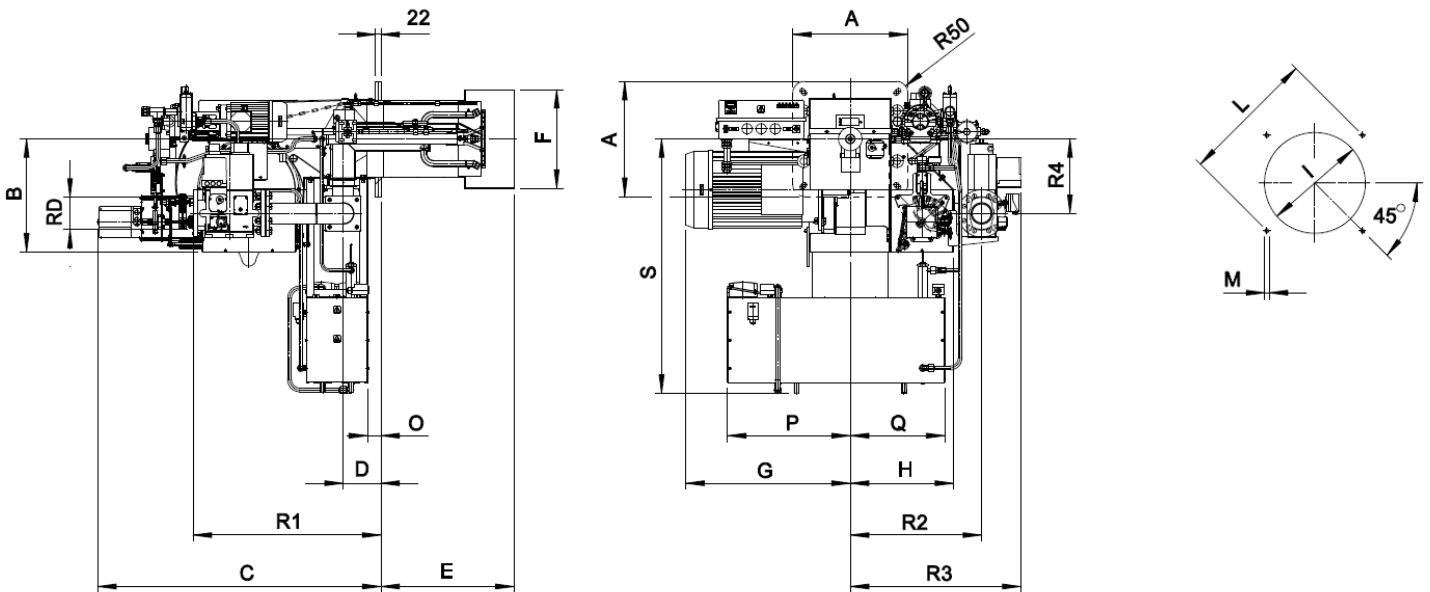

* Suggested dimension of connection between burner and generator

MODEL	A	B	C	D	E	F	G	H	I min	I*	I max	M	L min	L*	L max	O	P	Q	S	R1	R2	R3	R4	RD	Gas train weight
KN 190/M - D2"	360	453	1100	145	480	265	520	363	280	280	320	M14	396	424	438	93	403	403	790	504	509	672	260	D2"	22 kg
KN 190/M - DN65 - FS65	360	453	1100	145	480	265	520	363	280	280	320	M14	396	424	438	93	403	403	790	688	480	634	260	DN65	37 kg
KN 190/M - DN80 - FS80	360	453	1100	145	480	265	520	363	280	280	320	M14	396	424	438	93	403	403	790	708	480	648	260	DN80	47 kg
KN 190/M - DN100 - FS100	360	453	1100	145	480	265	520	363	280	280	320	M14	396	424	438	93	403	403	790	748	480	655	260	DN100	57 kg
KN 250/M - D2"	360	453	1100	145	480	265	520	363	280	280	320	M14	396	424	438	93	403	403	790	504	509	672	260	D2"	22 kg
KN 250/M - DN65 - FS65	360	453	1100	145	480	265	520	363	280	280	320	M14	396	424	438	93	403	403	790	688	480	634	260	DN65	37 kg
KN 250/M - DN80 - FS80	360	453	1100	145	480	265	520	363	280	280	320	M14	396	424	438	93	403	403	790	708	480	648	260	DN80	47 kg
KN 250/M - DN100 - FS100	360	453	1100	145	480	265	520	363	280	280	320	M14	396	424	438	93	403	403	790	748	480	655	260	DN100	57 kg