

REGO®



**LP-Gas
Serviceman's
Manual**

The LP-Gas Serviceman's Manual

RegO[®], has prepared this LP-Gas Serviceman's Manual for use by installation servicemen and others requiring a handy reference for field service work. It deals with subjects that can be useful to field servicemen striving for greater efficiency and safer installations. For the more technical problems and theories, the many texts and manuals concerning the particular subject should be consulted.

This manual is not intended to conflict with federal, state, or local ordinances and regulations. These should be observed at all times.

This information is intended to be forwarded throughout the product distribution chain. Additional copies are available from RegO[®] Products Master Distributors.

The logo for REGO, featuring the word "REGO" in a bold, blue, italicized sans-serif font with a registered trademark symbol (®) to the right.

Contents

Information About LP-Gas*.....	3
Vapor Pressures of LP-Gases*	4
Installation Planning	5
Propane Storage Vessels.....	5
Determining Total Load	6
100 LB. Cylinders	7
ASME Storage Containers	8
Proper Purging of LP-Gas Containers	9
Proper Placement of Cylinders and Tanks....	13
Pipe And Tubing Selection	16
LP-Gas Regulators.....	27
Leak Testing the Installation	36
Proper Use of Excess Flow Valves	40
Pressure Relief Valves	41
Repair of the MultiBonnet®	43
Flow of LP-Gas Through Fixed Orifices	45
Line Sizing Chart for Liquid Propane	46
Representative Equivalent Lengths of Pipe for Various Valves and Fittings.....	47
Determining Age of RegO® Products	48
Conversion Units	50

Information About LP-Gas*

	Propane	Butane
Formula	C ₃ H ₈	C ₄ H ₁₀
Boiling Point, °F	-44	15
Specific Gravity of Gas (Air=1.00)	1.50	2.01
Specific Gravity of Liquid (Water=1.00)	0.504	0.582
Lbs. per Gallon of Liquid at 60° F	4.20	4.81
BTU per Gallon of Liquid at 60° F	91502	102032
BTU per Lb. of Gas or Liquid	21548	21221
BTU per Cu. Ft. of Gas at 60° F	2488	3280
Cu. Ft. Vapor (at 60°F and 14.7 PSIA)/Gal. Liq	36.38	31.26
Cu. Ft. Vapor (at 60°F and 14.7 PSIA)/Lb. Liq	8.66	6.51
Cu. Ft. Vapor (at 60°F and 14.7 PSIA)/Cu. Ft. of Liq	272	234
Latent Heat of Vaporization at Boiling Point BTU/Gal.	773	808
Combustion Data:		
Cu. Ft. Air Required to Burn 1 Cu. Ft. Gas	23.86	31.02
Flash Point, °F	-156	N.A.
Ignition Temperature in Air, °F	920-1120	900-1000
Maximum Flame Temperature in Air, °F	3595	3615
Limits of Flammability Percentage of Gas in Air Mixture;		
At Lower Limit – %	2.15	1.55
At Upper Limit – %	9.6	8.6
Octane Number (ISO-Octane=100)	Over 100	92

*Commercial quality. Figures shown in this chart represent average values.

Vapor Pressures of LP-Gases*

Temperature		Approximate Pressure (PSIG)	
(°F)	(°C)	Propane	Butane
-30	-34	8	
-20	-29	13.5	
-10	-23	23.3	
0	-18	28	
10	-12	37	
20	-7	47	
30	-1	58	
40	4	72	3.0
50	10	86	6.9
60	16	102	12
70	21	127	17
80	27	140	23
90	32	165	29
100	38	196	36
110	43	220	45

*Conversion Formula:

$$\text{Degrees C} = (\text{°F} - 32) \times \frac{5}{9}$$

$$\text{Degrees F} = \frac{9}{5} \times \text{°C} + 32$$

Installation Planning

Propane Storage Vessels

The withdrawal of propane vapor from a vessel lowers the contained pressure. This causes the liquid to “boil” in an effort to restore the pressure by generating vapor to replace that which was withdrawn. The required “latent heat of vaporization” is surrendered by the liquid and causes the temperature of the liquid to drop as a result of the heat so expended.

The heat lost due to the vaporization of the liquid is replaced by the heat in the air surrounding the container. This heat is transferred from the air through the metal surface of the vessel into the liquid. The area of the vessel in contact with vapor is not considered because the heat absorbed by the vapor is negligible. The surface area of the vessel that is bathed in liquid is known as the “wetted surface.” The greater this wetted surface, or in other words the greater the amount of liquid in the vessel, the greater the vaporization capacity of the system. A larger container would have a larger wetted surface area and therefore would have greater vaporizing capacity. If the liquid in the vessel receives heat for vaporization from the outside air, the higher the outside air temperature, the higher the vaporization rate of the system. How all this affects the vaporization rate of 100-pound cylinders is shown on page 7. It will be noted from this chart that the worst conditions for vaporization rate are when the container has a small amount of liquid in it and the outside air temperature is low.

With the principles stated above in mind, simple formulae for determining the proper number of DOT cylinders and proper size of ASME storage containers for various loads where temperatures may reach 0°F will be found on pages 7 and 8 respectively.

Determining Total Load

In order to properly size the storage container, regulator, and piping, the total BTU load must be determined. The total load is the sum of all gas usage in the installation. It is arrived at by adding up the BTU input of all appliances in the installation. The BTU input may be obtained from the nameplate on the appliance or from the manufacturers' literature.

Future appliances which may be installed should also be considered when planning the initial installation to eliminate the need for a later revision of piping and storage facilities.

Where it may be more desirable to have ratings expressed in CFH, divide the total BTU load by 2488 for CFH of propane.

Approximate BTU Input For Some Common Appliances

Appliance	Approx. Input (BTU per Hour)
Range, free standing, domestic	65,000
Built-in oven or broiler unit, domestic	25,000
Built-in top unit, domestic	40,000
Water Heater, (Quick Recovery) automatic storage—	
30 Gallon Tank	30,000
40 Gallon Tank	38,000
50 Gallon Tank	50,000
Water Heater, automatic instantaneous	
Capacity (2 gal. per minute)	142,800
(4 gal. per minute)	285,000
(6 gal. per minute)	428,400
Refrigerator	3,000
Clothes Dryer, Domestic	35,000
Gas Light	2,500
Gas Logs	30,000

100 LB. Cylinders

How Many Are Required

“Rule of Thumb” Guide for
Installing 100 Lb. Cylinders

For continuous draws where temperatures may reach 0°F. Assume the vaporization rate of a 100 lb. cylinder as approximately 50,000 BTU per hour.

$$\text{Number of cylinders per side} = \frac{\text{Total load in BTU}}{50,000}$$

Example:

Assume total load = 200,000 BTU/hr.

$$\text{Cylinders per side} = \frac{200,000}{50,000} = 4 \text{ cylinders per side}$$

Vaporization Rate - 100 Lb. Propane Cylinders (Approximate)

Lbs. of Propane In Cyl.	Maximum Continuous Draw In BTU Per Hour At Various Temperatures In Degrees F.				
	0°F	20°F	40°F	60°F	70°F
100	113,000	167,000	214,000	277,000	300,000
90	104,000	152,000	200,000	247,000	277,000
80	94,000	137,000	180,000	214,000	236,000
70	83,000	122,000	160,000	199,000	214,000
60	75,000	109,000	140,000	176,000	192,000
50	64,000	94,000	125,000	154,000	167,000
40	55,000	79,000	105,000	131,000	141,000
30	45,000	66,000	85,000	107,000	118,000
20	36,000	51,000	68,000	83,000	92,000
10	28,000	38,000	49,000	60,000	66,000

This chart shows the vaporization rate of containers in terms of the temperature of the liquid and the wet surface area of the container. When the temperature is lower or if the container has less liquid in it, the vaporization rate of the container is a lower value.

ASME Storage Containers

Determining Propane Vaporization Capacity

“Rule of Thumb” Guide for ASME LP-Gas Storage Containers

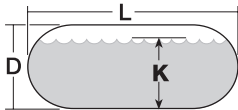

Where

D = Outside diameter in inches

L = Overall length in inches

K = Constant for percent volume
of liquid in container

Percentage of Container Filled	K Equals	*Propane Vaporization Capacity at 0°F (in BTU/hr.)
60	100	D X L X 100
50	90	D X L X 90
40	80	D X L X 80
30	70	D X L X 70
20	60	D X L X 60
10	45	D X L X 45

*These formulae assume an air temperature of 0° F. for vaporizing at other temperatures, see the chart below. The vapor space area of the vessel is not considered. Its effect is negligible.

Vaporizing Capacities For Other Air Temperatures (Temperature Factor)

Multiply the results obtained with the above formulae by one of the following factors for the prevailing air temperature.

Prevailing Air Temperature	Multiplier	Prevailing Air Temperature	Multiplier
-15°F	0.25	+5°F	1.25
-10°F	0.50	+10°F	1.50
-5°F	0.75	+15°F	1.75
0°F	1.00	+20°F	2.00

Proper Purging of LP-Gas Containers

The Importance of Purging

A very important step which must not be overlooked by LP-Gas distributors is the importance of properly purging new LP-Gas containers. Attention to this important procedure will promote customer satisfaction and greatly reduce service calls on new installations. Consider the following:

- Both ASME and DOT specifications require hydrostatic testing of vessels after fabrication. This is usually done with water.
- Before charging with propane, the vessel will contain the normal amount of air.

Both water and air are contaminants

They seriously interfere with proper operation of the system and the connected appliances. If not removed, they will result in costly service calls and needless expense far exceeding the nominal cost of proper purging.

Neutralizing Moisture

Even if a careful inspection (using a flashlight) reveals no visible moisture, the container must still be neutralized, since dew may have formed on the walls; additionally, the contained air may have relative humidity up to 100%.

A rule of thumb for neutralizing moisture in an ASME container calls for the introduction of at least one pint of genuine absolute anhydrous methanol* (99.85% pure) for each 100 gal. of water capacity of the container. On this basis, the minimum volumes for typical containers would be as shown below:

Container Type	Minimum Volume Methanol Required
100 lb. ICC cylinder	1/8 pt. (2 fl. ozs.)
420 lb. ICC cylinder	1/2 pt. (8 fl. ozs.)
500 gal. tank	5 pts. (2 1/2 qts.)
1000 gal. tank	10 pts. (1 1/4 gal.)

* IMPORTANT-Avoid substitutes - they will not work. The secret of the effectiveness of methanol over all other alcohols is its high affinity for water plus a boiling point lower than all other alcohols, and most important: a boiling point lower than water.

Proper Purging of LP-Gas Containers

The Importance of Purging Air

If the natural volume of atmosphere in the vessel is not removed before the first fill, these problems will result:

- Installations made in spring and summer will experience excessive and false container pressures. This will cause the safety relief valve to open, blowing off the excess pressure.
- The air mixture present in the vapor space will be carried to the appliances. This may result in as many as 5 or more service calls from pilot light extinguishment.
- If a vapor return equalizing hose is not used, the contained air will be compressed above the liquid level, resulting in slow filling.
- If a vapor equalizing hose is used, the air, and any moisture it contains, will be transferred from the storage tank to the transport.

Additionally, if atmospheric air is properly purged from the storage tank;

- the storage tank will fill faster,
- appliances will perform more consistently
- relief valves will be less likely to pop off at consumer installations.

Never Purge with Liquid

The wrong way is of course the easiest way. Never purge a container with liquid propane. To do so causes the liquid to flash into vapor, chilling the container, and condensing any moisture vapor on the walls where it remains while the pressure is being blown down. Additionally, less than 50% or as little as 25% of the air will be removed by this easy but wrong method.

The correct procedure for purging air is shown on the following page.

Proper Purging of LP-Gas Containers

Purging of Air

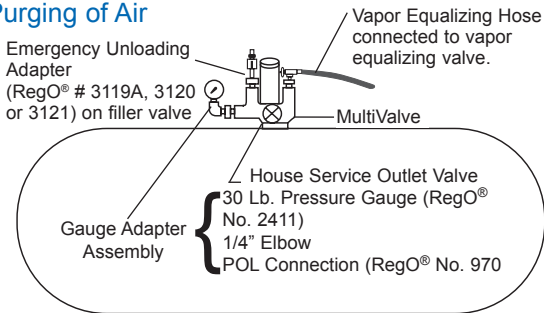

1. Install an unloading adapter on the double check filler valve, leaving it in the closed position.
2. Install a gauge adapter assembly on the service valve POL outlet connection. Exhaust to atmosphere any air pressure in the container.*(See page 12)
3. Attach a truck vapor equalizing hose to the vapor return valve on the container.
4. Open the valve on the outlet end of the vapor equalizing hose, throttling it to avoid slugging the excess flow valve on the truck. Carefully observe the pressure gauge.
5. When the gauge reading shows 15 psig, shut off the vapor valve on the hose.
6. Switch the lever on the unloading adapter to open the double check filler valve and blow down to exhaustion.
7. Close unloading adapter lever, allowing the double check filler valve to close.
8. Repeat steps (4), (5), (6), and (7) FOUR MORE TIMES. Total required time is 15 minutes or less.

CAUTION:

Never purge the container in this manner on the customer's property. Discharge of the vapor into the atmosphere can seriously contaminate the surrounding area. It should in all cases be done on the bulk plant site.

Proper Purging of LP-Gas Containers

Here's What Happened

While performing the operations shown on the preceding page, the percent of air in the container was reduced as shown in the table below:

	% Air Remaining	% Propane Remaining
1 st Purging	50	50
2 nd Purging	25	75
3 rd Purging	12.5	87.5
4 th Purging	6.25	93.75
5 th Purging	3.13	96.87
6 th Purging	1.56	98.44

Experience indicates that a reduction of the residual air content to 6.25% is adequate. The resulting mixture will have a thermal value of about 2400 BTU. In this case, the serviceman can adjust the burners for a slightly richer product. Moreover, the slight volume of air will to some extent dissolve in the propane if the installation stands unused for a few days.

How much Product was Consumed

If instructions on the preceding page were carefully followed and the vapor was purged five times, a total of 670 cu. ft. (18.4 gal) would have been used for a 1000 gallon tank. In a 500 gallon tank, a total of 9.2 gallons would have been used.

DOT Cylinder Purging

1. Exhaust to atmosphere any air pressure in the container*
2. Pressurize the cylinder to 15 psig propane vapor
3. Exhaust vapor to atmosphere
4. Repeat four more times

* Pre-Purged containers

For LP-Gas containers that are purchased pre-purged it is not necessary to follow the purging procedure previously shown in this handbook. Simply attach an adapter onto the POL service connection and introduce propane vapor into the container. Allow container pressure to reach at least 15 psig before disconnecting the adapter. Air and moisture have already been removed from pre-purged containers.

For more information, contact your local container supplier.

Proper Placement of Cylinders and Tanks

After the proper number of DOT cylinders or proper size of ASME storage containers has been determined, care must be taken in selecting the most accessible, but “safety approved” site for their location.

Consideration should be given to the customer’s desires as to location of LP-Gas containers, and the ease of exchanging cylinders or refilling the storage tanks with the delivery truck—BUT precedence must be given to state and local regulations and NFPA 58, Liquefied Petroleum Gas Code. Refer to this standard when planning placement of LP-Gas containers. Copies are available from the National Fire Protection Association, Batterymarch Park, Quincy, MA 02269.

The charts on the following [pages](#) are reprinted with permission of NFPA 58, LP-Gas Code, Copyright ©, National Fire Protection Association, Quincy, MA 02269. This reprinted material is not the complete and official position of the NFPA on the referenced subject which is represented only by the standard in its entirety.

Location of DOT Cylinders

From NFPA 58, Appendix I

Federal, state, and local ordinances and regulations should be observed at all times.

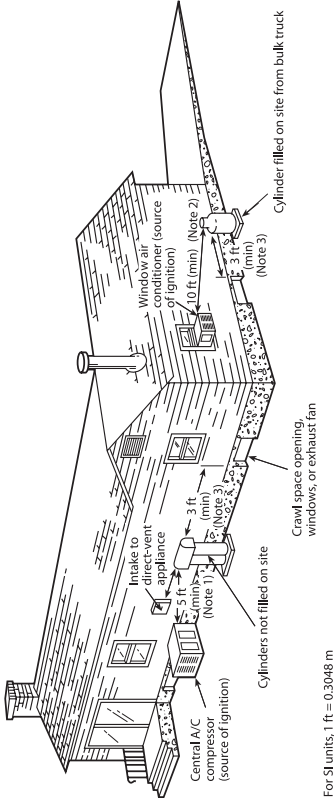

Notes:

- 1) 5-ft minimum from relief valve in any direction away from exterior source if ignition, openings into direct-vent gas appliances, or mechanical ventilation air intakes.
- 2) If the cylinder is filled on site from a bulk truck, the filling connection and vent valve must be at least 10 ft from any exterior source of ignition, openings into direct-vent gas appliances, or mechanical ventilation air intakes.
- 3) Cylinders installed along side buildings the relief valve discharge must be:
 - (a) At least 3 ft horizontally away from any building openings that is below level of the relief valve discharge.
 - (b) For cylinders not filled on site the relief valve discharge must be at least 5 ft from any exterior source of ignition, openings into direct-vent gas appliances, or mechanical ventilation air intakes.

Reprinted with permission from NFPA 58-2004, Liquefied Petroleum Gas Code, Copyright © 2004, National Fire Protection Association, Quincy, MA 02269. This reprinted material is not the complete and official position of the NFPA on the referenced subject, which is represented only by the standard in its entirety.

Location of ASME Containers

From NFPA 58, Appendix I

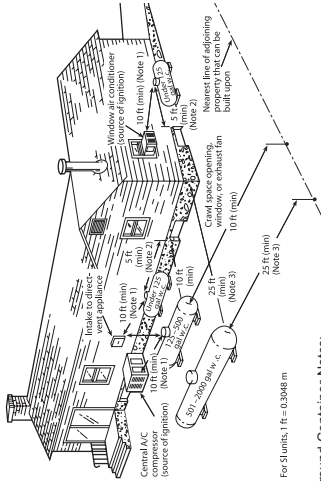
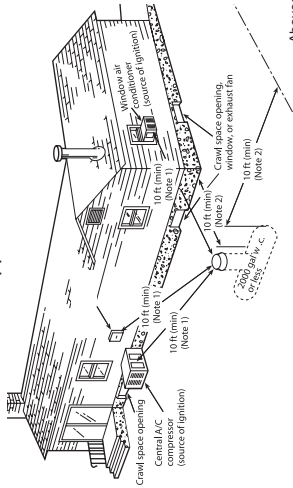

Underground Container Notes:

- 1) The relief valve, filling connection and liquid fixed liquid level gauge vent connection at the container must be at least 10 ft from any exterior source of ignition, openings into direct-vent gas appliances, or mechanical ventilation air intakes.
- 2) No part of the underground container shall be less than 10 ft from any important building or line of adjoining property that can be built upon.

Aboveground Container Notes:

- 1) Regardless of size, any ASME container filled on site must be located so that the filling connection filling connection and liquid fixed liquid level gauge vent connection at the container must be at least 10 ft from any exterior source of ignition, openings into direct-vent gas appliances, or mechanical ventilation air intakes.
- 2) The distance is measured horizontally from the point of discharge of the container pressure relief valve to any building opening below the level of the relief valve discharge.
- 3) This distance may be reduced to no less than 10 ft for a single container of 1200 gallon water capacity or less, if the container is located at least 25 feet from any other LP-Gas container of not more than 125 gallon water capacity.

Reprinted with permission from NFPA 58-2004, Liquefied Petroleum Gas Code, Copyright © 2004, National Fire Protection Association, Quincy, MA 02269. This reprinted material is not the complete and official position of the NFPA on the referenced subject, which is represented only by the standard in its entirety.

Pipe And Tubing Selection

Use the following simple method to assure the selection of the correct sizes of piping and tubing for LP-Gas vapor systems. Piping between the first and second stage is considered, as well as lower pressure (2 PSIG) piping between the 2 PSIG second stage or integral twin stage regulator and the line pressure regulator; and low pressure (inches of water column) piping between second stage, single stage, or integral twin stage regulators and appliances. The information supplied below is from NFPA 54 (National Fuel Gas Code) Appendix C, and NFPA 58 (Liquefied Petroleum Gas Code) Chapter 15; it can also be found in CETP (Certified Employee Training Program) published by the Propane Education and Research Council “Selecting Piping and Tubing” module 4.1.8. These illustrations are for demonstrative purposes, they are not intended for actual system design.

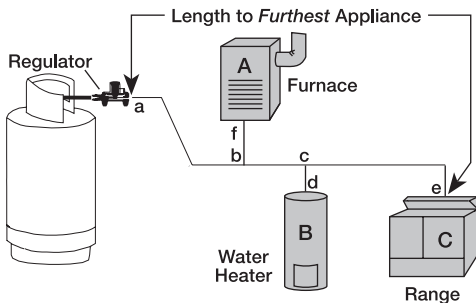

Pipe And Tubing Selection

- D. Using Table 3 select proper size of tubing or pipe for each section of piping, using values in BTU/hr for the length determined from step #2-A. If exact length is not on chart, use next longer length. Do not use any other length for this purpose! Simply select the size that shows at least as much capacity as needed for each piping section.
3. For piping between first and second stage regulators
 - A. For a simple system with only one second stage regulator, merely measure length of piping required between outlet of first stage regulator and inlet of second stage regulator. Select piping or tubing required from Table 1.
 - B. For systems with multiple second stage regulators, measure length of piping required to reach the second stage regulator that is furthest away. Make a simple sketch, and size each leg of piping using Table 1, 2, or 3 using values shown in column corresponding to the length as measured above, same as when handling second stage piping.

Pipe And Tubing Selection

Example 1.

Determine the sizes of piping or tubing required for the twin-stage LP-Gas installation shown.

Total piping length = 84 feet (use Table 3 @90 feet)

From a to b, demand = 38,000 + 35,000 + 30,000
= 103,000 BTU/hr; use 3/4" pipe

From b to c, demand = 38,000 + 35,000
= 73,000 BTU/hr; use 1/2" pipe or 3/4" tubing

From c to d, demand = 35,000 BTU/hr; use 1/2" pipe or 5/8" tubing

From c to e, demand = 38,000 BTU/hr; use 1/2" pipe or 5/8" tubing

From b to f, demand = 30,000 BTU/hr; use 1/2" pipe or 1/2" tubing

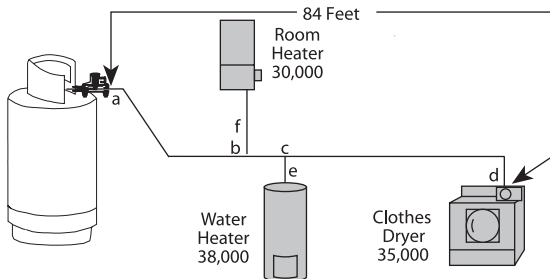

Pipe And Tubing Selection

Example 2.

Determine the sizes of piping or tubing required for the two-stage LP-Gas installation shown.

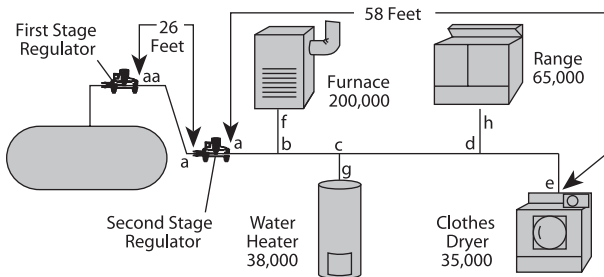

Total first stage piping length = 26 feet; first stage regulator setting is 10psig (use Table 1 or 2 @ 30 feet)

From aa to a, demand = 338,000 BTU/hr; use 1/2" pipe, 1/2" tubing, or 1/2" T plastic pipe.

Total second stage piping length = 58 feet (use Table 3 @ 60 feet)

From a to b, demand = 338,000 BTU/hr; use 1" pipe

From b to c, demand = 138,000 BTU/hr; use 3/4" pipe or 7/8" tubing

From c to d, demand = 100,000 BTU/hr; use 1/2" pipe or 3/4" tubing

From d to e, demand = 35,000 BTU/hr; use 1/2" pipe or 1/2" tubing

From b to f, demand = 200,000 BTU/hr; use 3/4" pipe or 7/8" tubing

From c to g, demand = 38,000 BTU/hr; use 1/2" pipe or 1/2" tubing

From d to h, demand = 65,000 BTU/hr; use 1/2" pipe or 5/8" tubing

Pipe And Tubing Selection

Example 3

Determine the sizes of piping or tubing required for the 2 PSI LP-Gas installation shown.

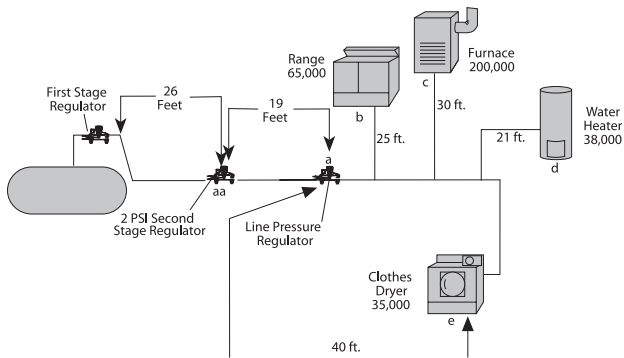

Total first stage piping length = 26 feet; first stage regulator setting is 10psig (use Table 1 or 2 @ 30 feet)

Total 2 PSI Piping Length = 19 ft. (use Table 4 @ 20 ft. or Table 6 @ 20 ft.)

From aa to a, demand = 338,000 BTU
use 3/8" CSST or 1/2" copper tubing or 1/2" pipe

From Regulator a to each appliance:

From a to b, demand = 65,000 BTU; length = 25 ft. (Table 5),
use 1/2" CSST

From a to c, demand = 200,000 BTU; length = 30 ft. (Table 5)
use 3/4" CSST

From a to d, demand = 38,000 BTU; length = 21 ft.* (Table 5)
use 3/8" CSST *use 25 ft. column

From a to e, demand = 35,000 BTU; length = 40 ft. (Table 5)
use 1/2" CSST

Table 1 – First Stage Pipe Sizing (Between First and Second Stage Regulators)

10 PSIG Inlet with a 1 PSIG Pressure Drop
Maximum capacity of pipe or tubing, in thousands of BTU/hr or LP-Gas

Size of Pipe or Copper Tubing, Inches	Length of Pipe or Tubing, Feet										
	10	20	30	40	50	60	70	80	90	100	
3/8"	558	383	309	265	235	213	196	182	171	161	
1/2"	1387	870	700	599	481	412	361	324	296	276	
5/8"	2360	1622	1303	1115	988	896	824	767	719	679	
3/4"	3993	2475	2205	1887	1672	1515	1394	1297	1217	1149	
1/2"	3339	2295	1843	1577	1398	1267	1165	1084	1017	961	
3/4"	6982	4799	3854	3298	2923	2649	2437	2267	2127	2009	
1"	13153	9040	7259	6213	5507	4989	4590	4270	4007	3785	
1 1/4"	27004	18660	14904	12756	11306	10244	9424	8767	8226	7770	
1 1/2"	40461	27809	22331	19113	16839	15348	14120	13136	12325	11642	
2"	77924	53556	43008	36809	32623	29559	27194	25299	23737	22422	

Size of Pipe or Copper Tubing, Inches	Length of Pipe or Tubing, Feet										
	125	150	175	200	225	250	275	300	350	400	
3/8"	142	130	118	111	104	90	89	89	82	76	
1/2"	323	293	269	251	235	222	211	201	185	172	
5/8"	601	546	502	467	438	414	393	375	345	321	
3/4"	1018	923	843	790	740	700	664	634	584	543	
1/2"	852	772	710	660	619	585	556	530	488	454	
3/4"	1780	1613	1484	1381	1296	1224	1162	1109	1020	949	
1"	3354	3039	2796	2601	2441	2305	2190	2089	1922	1788	
1 1/4"	6887	6240	5741	5340	5011	4733	4495	4289	3945	3670	
1 1/2"	10318	9349	8601	8002	7508	7092	6735	6426	5911	5499	
2"	19871	18005	16654	15410	14459	13658	12971	12375	11385	10591	

* Total length of piping from outlet of first stage regulator to inlet of second stage regulator (or to inlet of second stage regulator furthest away).

Notes: 1) To allow 2 PSIG pressure drop, multiply total gas demand by .707, and use capacities from table.

2) For different first stage pressures, multiply total gas demand by the following factors, and use capacities from table.

Ex: 1,000,000 BTU load at 5 PSI: 1,000,000 (1.12) = 1,200,000 BTU then use chart bases on 1,200,000 BTU

First Stage Pressure PSIG Multiply By

20 .844

15 .912

5 1.120

Data Calculated per NFPA #54 & 58

Table 2 – First Stage Plastic Tubing Sizing

10 PSIG Inlet with a 1 PSIG Pressure Drop

Maximum capacity of plastic tubing in thousands of BTU/hr of LP-Gas

Size of Plastic Tubing		Length of Tubing, Feet*									
NPS	SDR	10	20	30	40	50	60	70	80	90	100
½ CTS	7.00	1387	954	762	653	578	524	482	448	421	397
¾	9.33	3901	2681	2143	1835	1626	1473	1355	1261	1183	1117
1 CTS	11.00	7811	5369	4292	3673	3256	2950	2714	2525	2369	2238
1	11.00	9510	6536	5225	4472	3864	3391	3304	3074	2884	2724
1½	11.00	14094	9687	7744	6628	5874	5322	4896	4555	4274	4037
2	11.00	24416	16781	13416	11482	10106	9220	8433	7891	7404	6994
1½	11.00	-	-	20260	17340	15368	13924	12810	11918	11182	10562
2	11.00	66251	45534	36402	31155	27612	25019	23017	21413	20091	18978

Size of Plastic Tubing		Length of Tubing, Feet*									
NPS	SDR	125	150	175	200	225	250	275	300	350	400
½ CTS	7.00	352	319	294	273	256	242	230	219	202	188
¾	9.33	990	897	826	778	721	681	646	617	567	528
1 CTS	11.00	1983	1797	1653	1539	1443	1363	1294	1235	1136	1057
1	11.00	2414	2188	2013	1872	1757	1659	1576	1503	1383	1287
1½	11.00	3578	3242	2983	2775	2603	2459	2336	2228	2050	1907
2	11.00	6199	5616	5167	4807	4510	4260	4046	3860	3551	3304
1½	11.00	9361	8482	7803	7259	6811	6434	6111	5830	5363	4989
2	11.00	16920	15240	14020	13043	12238	11560	10979	10474	9636	8965

* Total length of piping from outlet of first stage regulator to inlet of second state regulator or to inlet of second stage regulator furthest away.

First Stage Pressure PSIG

Multiply By

20

.844

15

.912

5

1.120

Data Calculated per NFPA #54 & 58

Table 3 – Second Stage or Integral Twin Stage Pipe Sizing

11 Inches Water Column Inlet with a 1/2 Inch Water Column Drop
 Maximum capacity of pipe or tubing in thousands of BTU/hr of LP-Gas

Size of Pipe or Copper Tubing, Inches	Length of Pipe or Tubing, Feet											
	10	20	30	40	50	60	70	80	90	100		
Copper Tubing (O.D.)	3/8"	49	34	27	23	20	19	-	16	-	14	
	1/2"	110	76	61	52	46	42	38	36	33	32	
	5/8"	206	141	114	97	86	78	71	67	62	59	
	3/4"	348	239	192	164	146	132	120	113	105	100	
	7/8"	536	368	296	253	224	203	185	174	161	154	
Pipe Size	1"	608	418	336	287	255	231	212	198	185	175	
	1 1/4"	1146	788	632	541	480	435	400	372	349	330	
	1 1/2"	2353	1617	1299	1111	985	892	821	764	717	677	
	1 3/4"	3525	2423	1946	1665	1476	1337	1230	1144	1074	1014	
	2"	6789	4666	3747	3207	2842	2575	2369	2204	2068	1954	

Size of Pipe or Copper Tubing, Inches	Length of Pipe or Tubing, Feet											
	125	150	175	200	225	250	275	300	350	400		
Copper Tubing (O.D.)	3/8"	12	11	-	10	-	9	-	8	7		
	1/2"	28	26	-	22	-	19	-	18	15		
	5/8"	52	48	-	41	-	36	-	33	28		
	3/4"	89	80	-	69	-	61	-	55	47		
	7/8"	137	124	-	106	-	94	-	85	78		
Pipe Size	1"	74	67	62	58	54	51	48	46	40		
	1 1/4"	155	141	129	120	113	107	101	97	83		
	1 1/2"	292	265	244	227	213	201	191	182	167		
	1 3/4"	600	544	500	465	437	412	392	374	344		
	2"	899	815	749	697	654	618	587	560	515		
	1731	1569	1443	1343	1260	1190	1130	1078	992	923		

* Total length of piping from outlet of regulator to appliance furthest away.

Data Calculated per NFPA #54 & 58

Table 4-Maximum Capacity of CSST

In Thousands of BTU per hour of undiluted LP-Gases
Pressure of 2 psi and a pressure drop of 1 psi (Based on a 1.52 Specific Gravity Gas)*

Size	EHD** Flow Designation	Length of Pipe or Tubing, Feet														
		10	20	30	40	50	75	80	110	150	200	250	300	400	500	
¾"	13	426	262	238	203	181	147	140	124	101	86	77	69	60	53	
	15	558	347	316	271	243	196	189	169	137	118	105	96	82	72	
½"	18	927	591	540	469	420	344	333	298	245	213	191	173	151	135	
	19	1106	701	640	554	496	406	393	350	287	248	222	203	175	158	
¾"	23	1735	1120	1027	896	806	663	643	578	477	415	373	343	298	268	
	25	2168	1384	1266	1100	986	809	768	703	575	501	448	411	355	319	
1"	30	4097	2560	2331	2012	1794	1457	1410	1256	1021	880	785	716	616	550	
	31	4720	2954	2692	2323	2072	1685	1629	1454	1182	1019	910	829	716	638	

Table does not include effect of pressure drop across the line regulator. If regulator loss exceeds 1/2 psi (based on 13 in. water column outlet pressure), DO NOT USE THIS TABLE. Consult with regulator manufacturer for pressure drops and capacity factors. Pressure drops across a regulator may vary with flow rate.

CAUTION: Capacities shown in table may exceed maximum capacity for a selected regulator. Consult with regulator or tubing manufacturer for guidance.

*Table includes losses for four 90-degree bends and two end fittings. Tubing runs with larger number of bends and/or fittings shall be increased by an equivalent length of tubing according to the following equation: $L \cdot 1.3n$ where L is additional length (ft) of tubing and n is the number of additional fittings and/or bends.

**EHD — Equivalent Hydraulic Diameter — A measure of the relative hydraulic efficiency between different tubing sizes. The greater the value of EHD, the greater the gas capacity of the tubing.

Table 5-Maximum Capacity of CSST

In Thousands of BTU per hour of undiluted LP-Gases
Pressure of 11 Inch Water Column and a Pressure Drop of 0.5 Inch Water Column
(Based on a 1.52 Specific Gravity Gas)*

Size	EHD** Flow Designation	Length of Pipe or Tubing, Feet																
		5	10	15	20	25	30	40	50	60	70	80	90	100	150	200	250	300
¾"	13	72	50	39	34	30	28	23	20	19	17	15	15	14	11	9	8	8
	15	99	69	55	49	42	39	33	30	26	25	23	22	20	15	14	12	11
½"	18	181	129	104	91	82	74	64	58	53	49	45	44	41	31	28	25	23
	19	211	150	121	106	94	87	74	66	60	57	52	50	47	36	33	30	26
¾"	23	355	254	208	183	164	151	131	118	107	99	94	90	85	66	60	53	50
	25	426	303	248	216	192	177	153	137	126	117	109	102	98	75	69	61	57
1"	30	744	521	422	365	325	297	256	227	207	191	178	169	159	123	112	99	90
	31	863	605	490	425	379	344	297	265	241	222	208	197	186	143	129	117	107

*Table includes losses for four 90-degree bends and two end fittings. Tubing runs with larger number of bends and/or fittings shall be increased by an equivalent length of tubing according to the following equation: $L = 1.3n$ where L is additional length (ft) of tubing and n is the number of additional fittings and/or bends.

**EHD — Equivalent Hydraulic Diameter — A measure of the relative hydraulic efficiency between different tubing sizes. The greater the value of EHD, the greater the gas capacity of the tubing.

Table 6 – Copper Tube Sizing or Schedule 40 Pipe Sizing*

In Thousands of BTU per hour of undiluted LP-Gases
2 PSIG inlet with a 1PSIG pressure drop

Size of Pipe or Copper Tubing, Inches	Length of Pipe or Tubing, Feet												
	10	20	30	40	50	60	70	80	90	100			
Copper Tubing	3/8"	451	310	249	213	189	171	157	146	137	130		
	1/2"	1020	701	563	482	427	387	356	331	311	294		
Copper Tubing (O.D.)	5/8"	1900	1306	1049	898	795	721	663	617	579	547		
	3/4"	3215	2210	1774	1519	1346	1219	1122	1044	979	925		
	1/2"	2687	1847	1483	1269	1125	1019	938	872	819	773		
	3/4"	5619	3862	3101	2654	2352	2131	1961	1824	1712	1617		
Pipe Size	1"	10985	7275	5842	5000	4431	4015	3694	3436	3224	3046		
	1 1/4"	21731	14936	11994	10265	9098	8243	7584	7055	6620	6253		
	1 1/2"	32560	22378	17971	15381	13632	12351	11363	10571	9918	9369		
	2"	62708	43099	34610	29621	26253	23787	21884	20359	19102	18043		
Size of Pipe or Copper Tubing, Inches	150	200	250	300	350	400	450	500	600	700			
Copper Tubing (O.D.)	3/4"	104	89	79	72	66	61	58	54	49	45		
	1/2"	236	202	179	162	149	139	130	123	111	102		
	5/8"	439	376	333	302	278	258	242	229	207	191		
	3/4"	743	636	563	511	470	437	410	387	351	323		
Pipe Size	1/2"	621	531	471	427	393	365	343	324	293	270		
	3/4"	1298	1111	985	892	821	764	717	677	613	564		
	1"	2446	2093	1855	1681	1546	1439	1350	1275	1155	1063		
	1 1/4"	5021	4298	3809	3451	3175	2954	2771	2618	2372	2182		
1 1/2"	7524	6439	5707	5171	4757	4426	4152	3922	3554	3270			
2"	14490	12401	10991	9959	9162	8523	7997	7554	6844	6297			

LP-Gas Regulators

The regulator truly is the heart of an LP-Gas installation. It must compensate for variations in tank pressure from as low as 8 psig to 220 psig – and still deliver a steady flow of LP-Gas at 11” w.c. to consuming appliances. The regulator must deliver this pressure despite a variable load from intermittent use of the appliances.

The use of a two-stage system offers the ultimate in pin-point regulation. Two-stage regulation can result in a more profitable LP-Gas operation for the dealer resulting from less maintenance and fewer installation call-backs.

Single Stage/Twin-Stage Regulation

NFPA 58 states that single stage regulators shall not be installed in fixed piping systems. This requirement includes systems for appliances on RVs, motor homes, manufactured housing, and food service vehicles. In these cases a twin-stage regulator must be used. The requirements do not apply to small outdoor cooking appliances, such as gas grills, provided the input rating is 100,000 BTU/hr or less.

Two Stage Regulation

Two-Stage regulation has these advantages:

Uniform Appliance Pressures

The installation of a two-stage system—one high pressure regulator at the container to compensate for varied inlet pressures, and one low pressure regulator at the building to supply a constant delivery pressure to the appliances—helps ensure maximum efficiency and trouble-free operation year round. Two-stage systems keep pressure variations within 1” w.c. at the appliances.

Reduced Freeze-ups/Service Calls

Regulator freeze-up occurs when moisture in the gas condenses and freezes on cold surfaces of the regulator nozzle. The nozzle becomes chilled when high pressure gas expands across it into the regulator body.

Two-stage systems can greatly reduce the possibility of freeze-ups and resulting service calls as the expansion of gas from tank pressure to 11” w.c. is divided into two steps, with less chilling effect at each regulator. In addition, after the gas exits the first-stage regulator and enters the first-stage transmission line, it

LP-Gas Regulators

picks up heat from the line, further reducing the possibility of second-stage freeze-up.

Economy of Installation

In a twin-stage system, transmission line piping between the container and the appliances must be large enough to accommodate the required volume of gas at 11" w.c.. In contrast, the line between the first and second-stage regulators in two-stage systems can be much smaller as it delivers gas at 10 psig to the second stage regulator. Often the savings in piping cost will pay for the second regulator.

In localities where winter temperatures are extremely low, attention should be given to the setting of the first stage regulator to avoid the possibility of propane vapors recondensing into liquid in the line downstream of the first-stage regulator. For instance, if temperatures reach as low as -20°F, the first-stage regulator should not be set higher than 10 psig. If temperatures reach as low as -35°F, the setting of the first-stage regulator should not be higher than 5 psig.

As an additional benefit, older single-stage systems can be easily converted to two-stage systems using existing supply lines when they prove inadequate to meet added loads.

Allowance for Future Appliances

A high degree of flexibility is offered in new installations of two-stage systems. Appliances can be added later to the present load—provided the high pressure regulator can handle the increase—by the addition of a second low pressure regulator. Since appliances can be regulated independently, demands from other parts of the installation will not affect their individual performances.

Regulator Lockup Troubleshooting

The Problem:

A new, properly installed RegO[®] regulator has a high lock-up, does not lock up, or is creeping.

This is often caused by foreign material on the regulator seat disc. Foreign material usually comes from system piping upstream of the regulator. This material prevents the inlet nipple from properly seating on the seat disc.

The Solution:

There is a simple procedure that can be completed in the field that will resolve the problems in most cases. This procedure should be

LP-Gas Regulators

done by qualified service personnel only. Once it has been determined that a new regulator has not properly locked up, the following steps should be followed: Reinstall the regulator, check for leaks and properly check the system.

Step 1

Hold the neck of the regulator body securely with a wrench. Remove the inlet with a second wrench by turning clockwise (left hand thread).

Save the inlet nipple and gasket for reassembly.

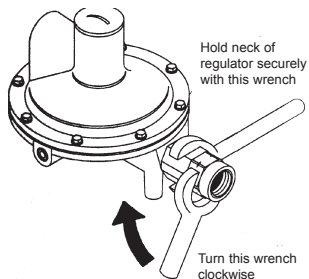

Step 2

Inspect the regulator seat disc. Wipe it clean using a dry, clean cloth.

Inspect the inlet nipple to be sure the seating surface is clean and not damaged.

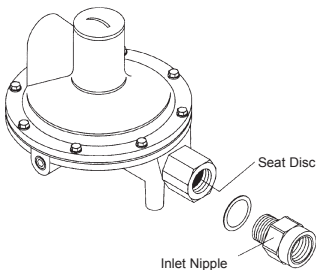

Step 3

Reinstall the inlet nipple and gasket by turning counterclockwise into neck of regulator (left hand thread).

Hold the neck of the regulator body secure with a wrench. Tighten the inlet nipple into the regulator with a second wrench. Tighten to 35 ft/lbs torque—do not overtighten.

Be careful not to damage threads.

After completing these steps, be sure system piping is clean and that new pig-tails are being used.

Reinstall the regulator, check for leaks and properly check the system.

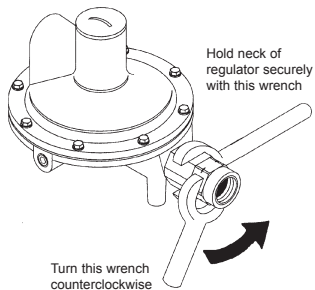

LP-Gas Regulators

Pigtails

If you are replacing an old regulator, remember to replace the copper pigtail. The old pigtail may contain corrosion which can restrict flow. In addition, corrosion may flake off and wedge between the regulator orifice and seat disc—preventing proper lock-up at zero flow.

Regulator Vents/Installation

The elements, such as freezing rain, sleet, snow, ice, mud, or debris, can obstruct the vent and prevent the regulator from operating properly. This can result in high pressure gas at the appliances resulting in explosion or fire.

Regulator vents must be clear and fully open at all times. Regulators installed in accordance with NFPA #58 will meet these requirements.

In general, regulators should be installed with the vent facing down and under a protective cover. Screened vents must be checked to see that the screen is in place at all times. If the vent is clogged or screen missing, cleaning of the vent and screen replacement is necessary. If there is evidence of foreign material inside the vent, the regulator should be replaced.

In applications where the regulator employs a vent discharge pipe, be sure it is installed with the outlet down and protected with a screen or suppressor. See RegO[®] Products Safety Warning in the L-500 and L-102 Catalogs for important warning information on regulators.

Second Stage Regulator Installation

Minimum Distances

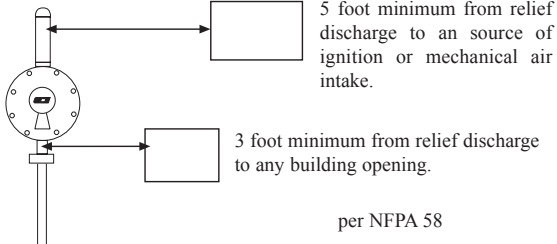

per NFPA 58

LP-Gas Regulators

Indoor Installation of Regulators

Regulators installed inside a building must have the bonnet vent piped away. To maintain the large vent capacity relief feature of the regulator, the vent piping should be at least as large as the vent opening on the regulator bonnet.

To pipe away the LV4403B or LV5503B regulators, for example, remove the vent screen from the bonnet vent and install 3/4" pipe into the bonnet vent threads and pipe to the outside of building. Install vent protection on the outlet of the pipe away vent line. To utilize the vent screen and retainer supplied with the regulator, use a 3/4" NPT 90° elbow. Insert screen into 3/4" F.NPT outlet of elbow. Thread retainer into outlet at least 1 turn. Install the elbow with vent screen pointing down. The vent line must be installed in a manner to prevent the entry of water, insects, or foreign material that could cause blockage. The discharge opening must be at least 3 feet from any opening below it.

NOTE: Do not use regulators with over 5 PSIG inlet pressure indoors. Follow all local codes and standards as well as NFPA 54 and 58.

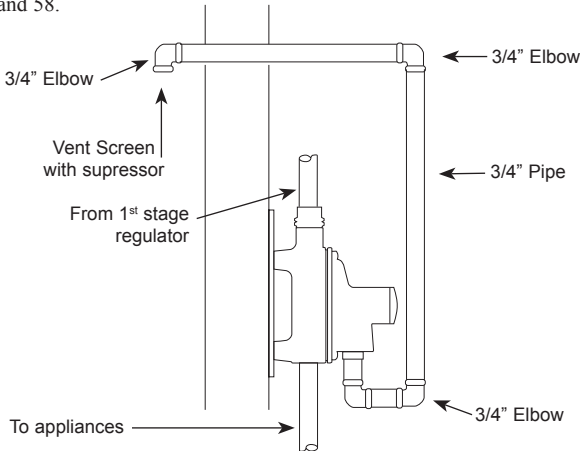

LP-Gas Regulators

Selecting LP-Gas Regulators

Type of System	Maximum Load	Suggested Regulator
First Stage in a Two Stage System	1,500,000 (a)	LV3403TR
	2,500,000 (b)	LV4403SR Series LV4403TR Series
Second Stage in a Two Stage System	935,000 (c)	LV4403B Series
	1,600,000 (c)	LV5503B4/B6
	2,300,000 (c)	LV5503B8
	9,800,000	LV6503B Series
	450,000	LV3403B Series
Second Stage in a 2 PSIG System	1,000,000	LV4403Y Y4/Y46R
	2,200,000	LV5503Y Y6/Y8
Integral Twin Stage	450,000 (d)	LV404B34/39 Series
	525,000 (d)	LV404B4/B9 Series
Integral Twin Stage 2PSIG	800,000	LV404Y9
Automatic Changeover	400,000 (d)	7525B34 Series
	450,000 (d)	7525B4 Series

- (a) Maximum load based on 25 PSIG inlet, 8 PSIG delivery pressure.
 (b) Maximum load based on inlet pressure 20 PSIG higher than setting and delivery pressure 20% lower than setting.
 (c) Maximum load based on 10 PSIG inlet, 9" w.c. delivery pressure.
 (d) Maximum load based on 25 PSIG inlet, 9" w.c. delivery pressure.

See RegO® Products Catalogs for complete ordering information.

LP-Gas Regulators

Underground Installations

In underground installations the vent tube opening must be above the maximum water table and kept free from water, insects, and foreign material. NOTE: if the water mark in the dome of an underground tank is above the regulator vent tube end or regulator vent opening, the regulator should be replaced and the situation corrected.

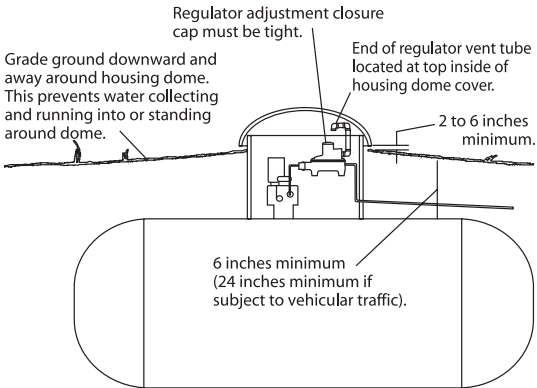

Reading a Regulator Performance Chart

Refer to the capacity chart for the size and type regulator which fits your particular application. Check the performance of this regulator with your actual load at the inlet pressure corresponding to your lowest winter temperatures (as shown on Page 4).

Example for a Two Stage System

Selecting the First Stage Regulator

1. Assume a load of 500,000 BTUs per hour
2. Assume a minimum delivery pressure of 9.5 psig.

LP-Gas Regulators

3. Assume a minimum tank pressure of 15 psig.
4. For these conditions, refer to chart for the LV4403TR Series, First Stage Regulator, shown below.
5. Find the line on the chart corresponding to the lowest anticipated winter tank pressure (note that each performance line corresponds to and is marked with a different inlet pressure in PSI).
6. Draw a vertical line upward from the point of assumed load (500,000 BTUs per hour) to intersect with the line corresponding to the lowest tank pressure.
7. Read horizontally from the intersection of these lines to the delivery pressure at the left side of the chart. In this example the delivery pressure will be 9.7 psig. Since the delivery pressure will be 9.7 psig at the maximum load conditions and lowest anticipated tank pressure, the regulator will be sized properly for the demand.

LV4403TR Series First Stage Regulator

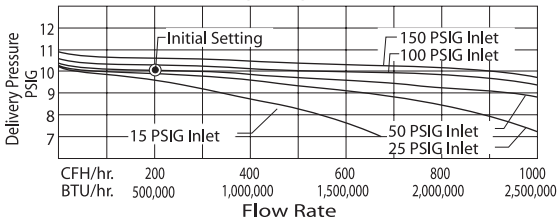

Example For a Two Stage System

Selecting the Second Stage Regulator

1. Assume a load of 250,000 BTUs per hour.
2. Assume a minimum delivery pressure of 10" w.c.
3. Assume a minimum inlet pressure of 10 psig.
4. For these conditions, refer to chart for the LV4403B Series, Second Stage Regulator, shown on next page.

LP-Gas Regulators

5. Find the line on the chart corresponding to the anticipated inlet pressure.
6. Draw a vertical line upward from the point of assumed load (250,000 BTUs per hour) to intersect with the line corresponding to the lowest inlet pressure.
7. Read horizontally from the intersection of these lines to the delivery pressure at the left side of the chart. In this example the delivery pressure will read 10.6" w.c.. Since the delivery pressure will be 10.6" w.c. at the maximum load condition and lowest anticipated inlet pressure, the regulator is sized properly for the demand.

LV4403B Series Second Stage Regulator

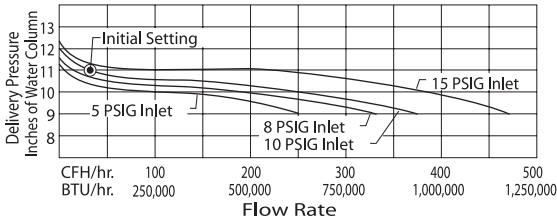

Leak Testing the Installation

According to NFPA 54:

A leak test should be performed on new installation and on existing systems that are being placed back into service. The test should include all piping, fittings, regulators, and control valves in the system.

Over the years, the pressure test and leak test have been confused with each other. A pressure test is required for new piping installation and additions to piping installation, while a leak test is required whenever the gas system is initially placed into service, or when the gas is turned back on after being turned off. In this handbook we discuss the leak test only. For further information regarding the pressure test, consult NFPA 54, National Fuel Gas Code.

Leak Testing the Installation

A. Manometer Method (Low Pressure Testing Procedure)

In this method a low pressure test gauge (RegO® 2434A) or a water manometer (1212Kit) is used to detect pressure loss due to leaks.

Step 1. Inspect all connections and appliance valves to be sure such connections are wrench tight and that all appliance connections are closed including pilot valves and all line shutoff valves.

Step 2. Connect low pressure test gauge or manometer to a range top burner orifice. If a range is not available a special tee may be installed between the appliance shutoff and inlet to the appliance. Several shutoff valves have a pressure tap port that may be used.

Step 3. Open container valve to pressure piping system. Leave it open for two or three seconds then close tightly. Return to appliances and open each appliance piping shutoff valve slowly. If the pressure drops below 10 inches water column repeat step 3.

Step 4. Observe indicated pressure on low pressure test set of manometer. This reading should be at least 11 inches water column. Now slowly open one burner valve on an appliance or bleed through a pilot valve enough gas to reduce pressure reading on the test set or water manometer to 9 +/-" water column.

A 3 minute constant pressure indicates a leak tight system. A drop in pressure indicates a leak in the system. If a drop occurs, check joints and other possible points of leakage with an approved combustible gas detector, soap and water, or an equivalent nonflammable solution. CAUTION: Since some leak test solutions, including soap and water, may cause corrosion or stress cracking, the piping should be rinsed with water after testing, unless it is determined the leak test solution is noncorrosive. Never test with an open flame. If there is an increase in pressure it indicates the container valve is not shut off completely. Shut off container valve tightly and repeat step 4.

Leak Testing the Installation

B. Gauge Adapter Method (High Pressure Testing Procedure)

Step 1. Inspect all connections and appliance valves to be sure such connections are wrench tight and that all appliance valves are closed including the pilot valves.

Step 2. Install 2962 high pressure test gauge adapter on the tank service valve and connect the other end of the gauge adapter to the pigtail and regulator inlet.

Step 3. Open container valve to allow the system to pressurize while observing indicated pressure on 300 pound testing gauge.

Step 4. Close service valve tightly. Note pressure reading on the pressure gauge, then slowly bleed gas between service valve and gauge adapter, reduce pressure to 10 PSIG less than the original reading on the gauge and retighten gauge adapter into service valve or close bleeder port. Note reading on gauge.

If gauge reading remains constant for 3 minutes, it can be assumed the system is leak tight. If the pressure reading drops, it indicates a leak somewhere in the high or low pressure piping system. NOTE: A pressure drop of 15 psig in 10 minutes time indicates a leak as little as 10 BTU of gas per hour. Check joints and other possible points of leakage with an approved combustible gas detector, soap and water, or an equivalent nonflammable solution. CAUTION: Since some leak test solutions, including soap and water, may cause corrosion or stress cracking, the piping should be rinsed with water after testing, unless it is determined the leak test solution is noncorrosive. Never test with an open flame. If there is an increase in pressure it indicates the container valve is not shut off completely. Shut off container valve tightly and repeat step 4.

Step 5. Disconnect the 2962 test gauge adapter from the service shut off valve. Reconnect pigtail, tighten and test with soap and water or an appropriate leak detector solution (refer to caution in step 4., above).

Step 6. If required, proceed with manometer method steps 2 through 4. Never check for leaks with an open flame.

Leak Testing the Installation

C. High Pressure Test Method. For service valves equipped with a pressure test port.

Step 1. Inspect all connections and appliance valves to be sure such connections are wrench tight and that all appliance valves are closed including the pilot valves.

Step 2. Install pressure test gauge on the test port down stream of the tank service valve seat and up stream of the pigtail and regulator inlet.

Step 3. Open container valve to allow the system to pressurize while observing indicated pressure on 300 pound testing gauge.

Step 4. Close service valve tightly. Note pressure reading on the pressure gauge, then slowly bleed gas between service valve and gauge adapter, reduce pressure to 10 PSIG less than the original reading on the gauge and retighten gauge adapter into service valve or close bleeder port. Note reading on gauge.

If gauge reading remains constant for 3 minutes, it can be assumed the system is leak tight. If the pressure reading drops, it indicates a leak somewhere in the high or low pressure piping system. NOTE: A pressure drop of 15 psig in 10 minutes time indicates a leak as little as 10 BTU of gas per hour. Check joints and other possible points of leakage with an approved combustible gas detector, soap and water, or an equivalent nonflammable solution. CAUTION: Since some leak test solutions, including soap and water, may cause corrosion or stress cracking, the piping should be rinsed with water after testing, unless it is determined the leak test solution is noncorrosive. Never test with an open flame. If there is an increase in pressure it indicates the container valve is not shut off completely. Shut off container valve tightly and repeat step 4.

Step 5. Disconnect the test gauge from the service shut off valve or leave it in place if desired. If gauge is removed plug the opening and check for leaks with an appropriate leak detector solution (refer to caution in step 4 above).

Step 6. If required, proceed with manometer method steps 2 through 4. Never check for leaks with an open flame.

Leak Testing the Installation

NOTE: After the piping system and appliance connections have been proven to be leak tight, the air may be purged from lines. Refer to NPGA Propane Safety and Technical Support Manual Bulletin T403 and NFPA 54 for more information.

Regulator Delivery Pressure

Check the regulator delivery pressure with approximately half the total appliance load in use. Your gauge should read 11 inches water column at the appliance. Adjust regulator if necessary. Following this, turn on all appliances to make sure that pressure is maintained at full load. If an excessive pressure drop occurs, inspect line for “kinks,” “flats,” or other restrictions.

CAUTION: Appliance regulators are installed on most appliances and may be preset by the manufacturer for flow pressure lower than 11 inches water column. It is recommended the manometer or test gauge be installed at a location other than the range orifice or appliance pressure tap when performing lockup and delivery pressure checks.

Regulator Lock-up and Leakage

After this, shut off all appliance valves to determine if the regulator has a worn seat or if it has been set too high to compensate for line losses due to undersize piping. A slight rise in pressure will occur under these conditions. This is called the “lock-up” pressure. The lock-up pressure should not exceed 130% of the regulator set delivery pressure. A quick rise in pressure above this point will indicate undersize piping.

Continue this same test for 5 minutes or more. If a creeping rise is noticed in the pressure, the regulator seat is not closing off properly. Inspect regulator inlet nozzle for dirt, scratches, or dents, and seat disc for signs of wear. Replace where necessary.

For more information, refer to NFPA 54, Section on Inspection, Testing and Purging, NPGA Propane Safety and Technical Support Manual Bulletin 403, “Pressure testing and leak checking LP Gas piping systems.” For more information on setting single stage regulators, request RegO[®] Products Technical Guide 107.

Proper Use of Excess Flow Valves

The primary purpose of an excess flow valve is to protect against excessive flow when breakage of pipe lines or hose rupture takes place. When we refer to breakage or rupture, a clean and complete separation is assumed. It is obvious that, if the damage is only a crack or if the piping is crushed at the point of failure, the escaping flow will be restricted and may or may not pass sufficient vapor or liquid to cause the excess flow valve to close.

An excess flow valve, while in its normal open position, permits the flow of liquid or gas in either direction. Flow is controlled in one direction only. Each excess flow valve is stamped with an arrow showing the direction in which the flow is controlled. If the flow in that direction exceeds a predetermined rate the valve automatically closes. Manufacturers' catalogs show the closing flow rating both in terms of liquid and vapor.

Since excess flow valves depend on flow for closure, the line leading away from the excess flow valve should be large enough so that it will not excessively restrict the flow. If the pipe run is unusually long or restricted by numerous elbows, tees, or other fittings, consideration should be given to the use of larger size pipe and fittings. Never use a pipe size smaller than that of the excess flow valve.

It is considered good practice to select an excess flow valve with a rated closing flow approximately 50% greater than the anticipated normal flow. This is important because valves which have a closing flow very close to the normal flow may chatter or slug closed when surges in the line occur either during normal operation or due to the rapid opening of a control valve.

Excess flow valves should be tested and proven at the time of installation and at periodic intervals not to exceed one year. The tests should include a simulated break in the line by the quick opening of a shutoff valve at the farthest possible point in the piping which the excess flow valve is intended to protect. If the valve closes under these conditions, it is reasonable to assume that it will close in the event of accidental breakage of the piping at any point closer to the excess flow valve.

See RegO[®] Products Safety Warning in the L-500 and L-102 Catalogs for important warning information

Pressure Relief Valves

Minimum required rate of discharge in cubic feet per minute of air at 120% of the maximum permitted start to discharge pressure for safety relief valves to be used on containers other than those constructed in accordance with Department of Transportation specification.

Surface Area Sq. Ft.	Flow Rate CFM Air	Surface Area Sq. Ft.	Flow Rate CFM Air	Surface Area Sq. Ft.	Flow Rate CFM Air
20 or less	626	170	3620	600	10170
25	751	175	3700	650	10860
30	872	180	3790	700	11550
35	990	185	3880	750	12220
40	1100	190	3960	800	12880
45	1220	195	4050	850	13540
50	1330	200	4130	900	14190
55	1430	210	4300	950	14830
60	1540	220	4470	1000	15470
65	1640	230	4630	1050	16100
70	1750	240	4800	1100	16720
75	1850	250	4960	1150	17350
80	1950	260	5130	1200	17960
85	2050	270	5290	1250	18570
90	2150	280	5450	1300	19180
95	2240	290	5610	1350	19780
100	2340	300	5760	1400	20380
105	2440	310	5920	1450	20980
110	2530	320	6080	1500	21570
115	2630	330	6230	1550	22160
120	2720	340	6390	1600	22740
125	2810	350	6540	1650	23320
130	2900	360	6690	1700	23900
135	2990	370	6840	1750	24470
140	3080	380	7000	1800	25050
145	3170	390	7150	1850	25620
150	3260	400	7300	1900	26180
155	3350	450	8040	1950	26750
160	3440	500	8760	2000	27310
165	3530	550	9470		

Pressure Relief Valves

Surface area = Total outside surface area of container in square feet.

When the surface area is not stamped on the nameplate or when the marking is not legible, the area can be calculated by using one of the following formulas:

- (1) Cylindrical container with hemispherical heads
Area = Overall length X outside diameter X 3.1416
- (2) Cylindrical container with semi-ellipsoidal heads
Area = (Overall length + .3 outside diameter) X outside diameter X 3.1416
- (3) Spherical container
Area = Outside diameter squared X 3.1416

Flow Rate-CFM Air = Required flow capacity in cubic feet per minute of air at standard conditions, 60°F and atmospheric pressure (14.7 psig).

The rate of discharge may be interpolated for intermediate values of surface area. For containers with total outside surface area greater than 2000 square feet, the required flow rate can be calculated using the formula:

$$\text{Flow Rate - CFM Air} = 53.632 A^{0.82}$$

Where A = total outside surface area of the container in square feet.

Valves not marked “Air” have flow rate marking in cubic feet per minute of liquefied petroleum gas. These can be converted to ratings in cubic feet per minute of air by multiplying the liquefied petroleum gas ratings by the factors listed below. Air flow ratings can be converted to ratings in cubic feet per minute of liquefied petroleum gas by dividing the air ratings by the factors listed below.

Air Conversion Factors

Container Type	<u>100</u>	<u>125</u>	<u>150</u>	<u>175</u>	<u>200</u>
Air Conversion Factor	1.162	1.142	1.113	1.078	1.010

See RegO® Products Safety Warning in the L-500 and L-102 Catalogs for important warning information.

Repair of the MultiBonnet®

The MultiBonnet® is designed to allow quick and easy repair of bonnet packings in MultiValves® and Service Valves on active propane systems. It eliminates the need to evacuate tanks or cylinders to repair the MultiBonnet® packing. The two section design allows repair on MultiBonnet® assembly without any interruption in gas service.

The following illustrates the repair of a MultiBonnet® in a RegO® MultiValve® or Service Valve that is on an active pressurized propane system. It is important that when actual repairs are conducted, the individual doing the repairs be completely familiar with and follow the 19104-800 instruction sheet included with the 19104-80 repair kit. These instructions **MUST** be followed. **ONLY** qualified personnel should attempt installation of the MultiBonnet® repair kit. Follow all federal, state, and local regulations.

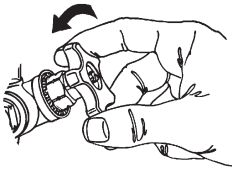

- 1** Turn handwheel counterclockwise as far as possible to assure valve is completely open and backseated.

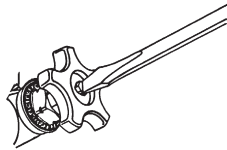

- 2** Remove self tapping screw and handwheel.

Repair of the MultiBonnet®

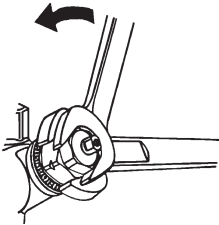

3

Holding the lower section of the MultiBonnet® in place with a wrench, use a second wrench to remove the upper bonnet packing assembly.

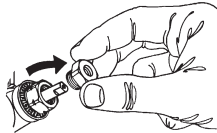

4

Thread the new upper bonnet packing assembly into the lower section of the MultiBonnet®.

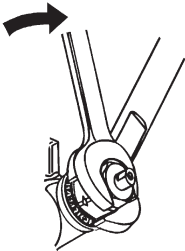

5

Tighten upper packing assembly with 50 to 75 inch/pounds torque.

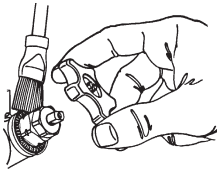

6

Reassemble the handwheel and check valve for leaks.

Flow of LP-Gas Through Fixed Orifices BTU Per Hour at 11" w.c. at Sea Level

Orifice or Drill Size	Propane	Butane	Orifice or Drill Size	Propane	Butane
.008	519	589	51	36,531	41,414
.009	656	744	50	39,842	45,168
.010	812	921	49	43,361	49,157
.011	981	1,112	48	46,983	53,263
.012	1,169	1,326	47	50,088	56,783
80	1,480	1,678	46	53,296	60,420
79	1,708	1,936	45	54,641	61,944
78	2,080	2,358	44	60,229	68,280
77	2,629	2,980	43	64,369	72,973
76	3,249	3,684	42	71,095	80,599
75	3,581	4,059	41	74,924	84,940
74	4,119	4,669	40	78,029	88,459
73	4,678	5,303	39	80,513	91,215
72	5,081	5,760	38	83,721	94,912
71	5,495	6,230	37	87,860	99,605
70	6,375	7,227	36	92,207	104,532
69	6,934	7,860	35	98,312	111,454
68	7,813	8,858	34	100,175	113,566
67	8,320	9,433	33	103,797	117,672
66	8,848	10,031	32	109,385	124,007
65	9,955	11,286	31	117,043	132,689
64	10,535	11,943	30	134,119	152,046
63	11,125	12,612	29	150,366	170,466
62	11,735	13,304	28	160,301	181,728
61	12,367	14,020	27	168,580	191,144
60	13,008	14,747	26	175,617	199,092
59	13,660	15,486	25	181,619	205,896
58	14,333	16,249	24	187,828	212,935
57	15,026	17,035	23	192,796	218,567
56	17,572	19,921	22	200,350	227,131
55	21,939	24,872	21	205,525	232,997
54	24,630	27,922	20	210,699	238,863
53	28,769	32,615	19	233,945	253,880
52	32,805	37,190	18	233,466	264,673

Reprinted with permission from NFPA 54, National Fuel Gas Code, Copyright©1999, National Fire Protection Association, Quincy, MA 02269. This reprinted material is not the complete and official position of the NFPA on the referenced subject which is represented only by the standard in its entirety.

Line Sizing Chart for Liquid Propane

(Based on Pressure Drop of 1 PSI)

Liquid Propane Flow GPH	Iron Pipe (Feet)															
	1/4"		3/8"		1/2"		3/4"		1"		1-1/4"		1-1/2"		2"	
	Schedule 40	Schedule 80	Schedule 40	Schedule 80	Schedule 40	Schedule 80	Schedule 40	Schedule 80	Schedule 40	Schedule 80	Schedule 40	Schedule 80	Schedule 40	Schedule 80	Schedule 40	Schedule 80
10	729	416														
15	324	185														
20	182	104	825	521												
40	46	26	205	129	745	504										
60	20	11	92	58	331	224										
80	11	6	51	32	187	127	735	537								
100	7	4	33	21	119	81	470	343								
120			23	15	83	56	326	238								
140			15	9	61	41	240	175	813	618						
160			13	8	47	32	184	134	623	473						
180					37	25	145	106	491	373						
200					30	20	118	86	399	303						
240					21	14	81	59	277	211						
280					15	10	60	44	204	155						
300					13	9	52	38	177	135	785	623				
350							38	28	130	99	578	459				
400							30	22	99	75	433	344	980	794		
500							19	14	64	49	283	225	627	508		
600									44	33	197	156	435	352		
700									32	24	144	114	320	259		
800									25	19	110	87	245	198	965	795
900									19	14	87	69	194	157	764	630
1000									16	12	71	56	157	127	618	509
1500											31	25	70	57	275	227
2000											18	14	39	32	154	127
3000											8	6	17	14	69	57
4000													10	8	39	32
5000															25	21
10000															6	5

To Use Chart

1. Having determined the required flow at point of use, locate this flow in the left hand column. If this falls between two figures, use the larger of the two.
2. Determine total length of piping required from source to point of use.
3. Read across chart from left (required flow) to right to find the total length which is equal to or exceeds the distance from source to use.
4. From this point read up to find the correct size of pipe required.

Representative Equivalent Lengths of Pipe for Various Valves and Fittings

Fitting	Equivalent Length of Steel Pipe (Feet)													
	Nominal Pipe Size (NPT)													
	3/4"		1"		1-1/4"		1-1/2"		2"		2-1/2"		3"	
Schedule	40	80	Schedule	40	80	Schedule	40	80	Schedule	40	80	Schedule	40	80
45° Screwed Elbow	1.8	1.6	2.3	2.1	2.9	3.7	3.4	4.6	4.4	5.3	5.1	6.9	6.5	8.0
90° Screwed Elbow	1.4	1.3	1.7	1.6	2.3	2.8	2.6	3.6	3.3	4.2	4.0	5.4	5.0	6.0
Screwed Tee Through Run	4.6	4.0	5.6	5.3	7.3	9.3	8.6	12.0	11.0	15.0	14.0	17.0	16.0	19.0
Screwed Tee Through Branch	14.0	10.0	21.0	16.0	19.0	39.0	27.0	42.0	34.5	24.0	20.0	46.0	39.0	46.0
Screwed Globe Valve*	11.0	8.0	13.0	10.0	10.5	20.0	16.0	32.0	26.5	7.5	6.0	19.0	16.0	19.0
Screwed Angle Valve*	---	---	---	---	---	30.0	24.0	41.0	34.0	---	---	46.0	39.0	46.0
Flanged Globe Valve*	---	---	---	---	---	12.0	10.0	14.5	12.0	---	---	19.0	16.0	19.0
Flanged Angle Valve*														

* RegO® A7500 Series Valves

Determining Age of RegO® Products

1960 to 1985 -- Two-Letter Date Code

First letter in date code is the month

A—January	G—July
B—February	H—August
C—March	I—September
D—April	J—October
E—May	K—November
F—June	L—December

Relief valves used on ASME tanks carry a numerical code indicating month and year such as 1-75 means January, 1975.

Second letter in date code is the year

R—1960	A—1969	J—1978
S—1961	B—1970	K—1979
T—1962	C—1971	L—1980
U—1963	D—1972	M—1981
V—1964	E—1973	N—1982
W—1965	F—1974	O—1983
X—1966	G—1975	P—1984
Y—1967	H—1976	Q—1985
Z—1968	I—1977	

Example: DL = April of 1980

1985 to 1990 -- Digit Date Code

First digit in date code is the month

1—January	7—July
2—February	8—August
3—March	9—September
4—April	10—October
5—May	11—November
6—June	12—December

Second 2 digits in date code are the year

86—1986	89—1989
87—1987	90—1990
88—1988	

Example: 5-87 = May of 1987

Determining Age of RegO® Products

After 1990 — Digit-Letter-Digit Date Code

First digit in date code is the month

1 — January	7 — July
2 — February	8 — August
3 — March	9 — September
4 — April	10 — October
5 — May	11 — November
6 — June	12 — December

Letter in date code
is the week

A — 1 st week
B — 2 nd week
C — 3 rd week
D — 4 th week
E — 5 th week

Second 2 digits in date code are the year

91 — 1991	98 — 1998
92 — 1992	99 — 1999
93 — 1993	00 — 2000
94 — 1994	01 — 2001
95 — 1995	etcetera . . .
96 — 1996	
97 — 1997	

Example: 6A92 = First week of June, 1992

Converting Volumes of Gas

(CFH to CFH or CFM to CFM)

Multiply Flow Of:	By	To Obtain Flow Of:
Air	0.707	Butane
	1.290	Natural Gas
	0.816	Propane
Butane	1.414	Air
	1.826	Natural Gas
	1.154	Propane
Natural Gas	0.775	Air
	0.547	Butane
	0.632	Propane
Propane	1.225	Air
	0.866	Butane
	1.580	Natural Gas

Conversion Units

Multiply	By	To Obtain
Pressure		
Atmospheres	1.0332	kilograms per sq. centimeter
Atmospheres	14.70	pounds per square inch
Atmospheres	407.14	inches water
Grams per sq. centimeter	0.0142	pounds per square inch
Inches of mercury	.4912	pounds per square inch
Inches of mercury	1.133	feet of water
Inches of water	0.0361	pounds per square inch
Inches of water	0.0735	inches of mercury
Inches of water	0.5781	ounces per square inch
Inches of water	5.204	pounds per square foot
bar	100	kPa
Kilograms per sq. centimeter	14.22	pounds per square inch
Kilograms per square meter	0.2048	pounds per square foot
Pounds per square inch	0.0680	atmospheres
Pounds per square inch	0.07031	kilograms per sq. centimeter
Pounds per square inch*	6.89	kPa
Pounds per square inch	2.036	inches of mercury
Pounds per square inch	2.307	feet of water
Pounds per square inch	.06897	bar
Pounds per square inch	27.67	inches of water
kPa	.145	PSI
Length		
Centimeters	0.3937	inches
Feet	0.3048	meters
Feet	30.48	centimeters
Feet	304.8	millimeters
Inches	2.540	centimeters
Inches	25.40	millimeters
Kilometer	0.6214	miles
Meters	1.094	yards
Meters	3.281	Feet
Meters	39.37	inches
Miles (nautical)	1,853.0	meters
Miles (statute)	1,609.0	meters
Yards	0.9144	meters
Yards	91.44	centimeters

*Ex. 5 pounds per square inch X (6.89) = 34.45 kPa

Conversion Units

Multiply	By	To Obtain
Volume		
Cubic centimeter	0.06103	cubic inch
Cubic feet	7.48	gallons (US)
Cubic feet	28.316	liters
Cubic feet	1728	cubic inches
Cubic feet	.03704	cubic yards
Cubic feet	.02832	cubic meters
Gallons (Imperial)	1.201	gallons (US)
Gallons (US)*	0.1337	cubic feet
Gallons (US)	0.8326	gallons (Imperial)
Gallons (US)	3.785	liters
Gallons (US)	231	cubic inches
Liters	0.0353	cubic feet
Liters	0.2642	gallons (US)
Liters	1.057	quarts (US)
Liters	2.113	pints (US)
Pints (US)	0.4732	liters
Miscellaneous		
BTU	252	calories
Calories	3.968	BTU
Ton (US)	2000	pounds
Kilogram	2.205	pounds
Kilowatt Hour	3412	BTU
Ounces	28.35	grams
Pounds	0.4536	kilograms
Pounds	453.5924	grams
Ton (US)	.908	tonne
Therm	100,000	BTU
API Bbls	42	gallons (US)

*Ex. 200 US gallons (.1337) = 26.74 cubic feet

REGO[®] ONLINE

www.regoproducts.com

• Distributor Information • Service Manuals

• Application Guides • Product Literature

• Product Updates • Technical Guides

Manual L-545 Copyright 1962 Revised 1/11

Printed in the USA 11-0111-0862

100 RegO Drive PO Box 247 Elon, NC 27244 USA
Phone (336) 449-7707 Fax (336) 449-6594